

EP-20 e/m of the Electron Apparatus



Figure 1

Introduction

This self-contained apparatus is designed for the measurement of e/m of the electron by observing the radius of the circular path under the influence of a uniform magnetic field. The magnetic field is provided by a pair of Helmholtz coils surrounding the vacuum tube. The vacuum tube has a downward pointing electron gun in an evacuated bulb that has a little helium added so that the path of the electrons in the tube is visible. The overall appearance of the apparatus is shown in figure 1.

Three internal power supplies provide the filament power, the coil current and the accelerating potential for the electron beam. The filament supply is fixed, while the accelerating voltage and the coil current are set by front panel controls. The accelerating potential and the coil current can be measured by digital meters on the front panel. The meters make it simple to accurately determine the forces affecting the motion of the electrons within the tube. The diameter of the electron path in the magnetic field can be measured using the etched glass internal scale in the tube. The graduations and numerals of the scale are

illuminated by the collision of the electrons, making observation and reading even easier.

The helium gas added to the tube fluoresces when struck by the moving electrons and produces a bright, clear view of the electron beam. An electrode is provided for absorbing electrons after they have traced their circular path. Thus, the circular tracing of the electron path is undisturbed by previously emitted electrons, contributing to more accurate measurement.

Tube Adjustment

Loosen the clamp pieces of the cradle between the Helmholtz coils, using the included Allen wrench. Be sure the spherical portion of the tube is concentric with the coils. In a darkened room, power up the apparatus, turning the voltage to a high enough level to produce an easily visible beam. Bend the beam into a circle by applying sufficient current to the coils. The plane of the beam should be vertical, and should intersect the the front of the calibrated glass rod. Gently rotate the tube in the cradle if adjustment is needed, lastly tightening the cradle bolts.

Principle of Operation

The general configuration of the electron gun is shown in fig. 2. Electrons are emitted by an indirectly heated cathode at the top of the figure. The cathode is connected to the negative of the high voltage supply. It is partially shielded by a surrounding grid which has a small aperture to let some electrons pass through. The anode is mounted below the grid and is connected to the high voltage positive. Electrons escaping through the grid hole are rapidly accelerated toward the anode by the potential between them. Most of the electrons hit the anode, but some of them pass through the hole in the anode and form the electron beam in the tube.

The energy given to the electron falling through the potential V is eV , where V is the cathode anode potential and e is the charge on the electron. All of this energy is converted into kinetic energy of the moving electron

$$\frac{1}{2} mv^2$$

So that

$$\frac{1}{2} mv^2 = eV$$

and

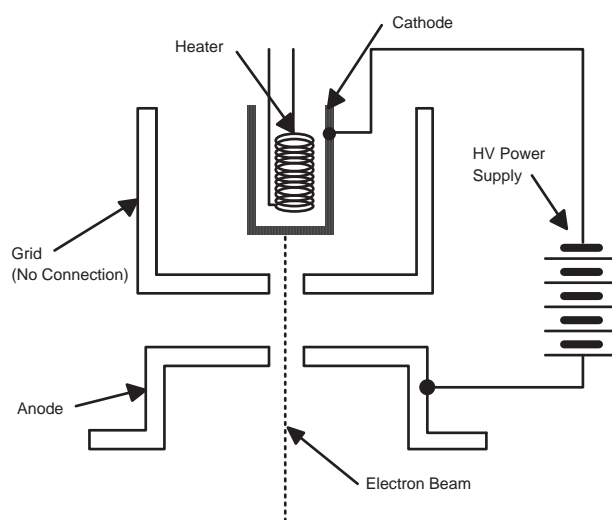

Figure 2

$$v = (2eV/m)^{1/2} \quad (1)$$

The electron beam is travelling in the transverse magnetic field of the Helmholtz coils, so it is deflected into a circular path by the Lorentz force, $e\mathbf{v}\mathbf{B}$, where \mathbf{B} is the magnetic field, acting on the current. This force provides the centripetal force, mv^2/r required to maintain the circular motion.

Equating these forces

$$e\mathbf{v}\mathbf{B} = mv^2/r$$

and

$$e\mathbf{B} = mv/r \quad (2)$$

From these two equations an expression for e/m can be derived

$$e/m = 2V/(r^2B^2) \quad (3)$$

The magnetic field is provided by the Helmholtz coils surrounding the vacuum tube. They are mounted so that their field is transverse to the tube axis and the electron's motion. These coils produce a uniform magnetic field everywhere inside of the volume they enclose. This is a very useful property, since it guarantees that there is a constant force on the moving electrons. In addition to field uniformity, the magnitude of the magnetic field can be calculated from

$$B = \{(\mu_0NI)/a\} \{4/5\}^{3/2}$$

where μ_0 is the permeability of empty space, N is the number of turns in each of the pair of coils, I is the coil current and a is the coil radius. For a typical set of coils in this apparatus, the number of turns is 132 per coil and the radius is 0.1475m so that,

$$B = 0.80 \text{ mT/Ampere}$$

Your coil radius will be a little different from this value, so measure the dimensions carefully.

Experimental Procedure

1. Set the apparatus on a level table. The room light should not be too bright, because the electron beam will be hard to see.
2. In order to minimize the influence of geomagnetism, use a compass to locate magnetic North and align the field of the Helmholtz coils so it is parallel to the needle.

This will have the effect of reducing the influence of geomagnetism on the magnetic field parallel to the coil axis. The influence of geomagnetism or other sources of magnetic fields can be observed by the deflection of the circular motion of the electron beam while the apparatus is rotated. The magnitude of this deflection is greater when a small current is flowing through the coils.

3. With the power switch off, connect the line cord to the correct line voltage power.
4. Turn on the power switch. The unit will perform a 30-second self-test, indicated by the digital display changing values rapidly. During the self-test, the controls are locked out, allowing the cathode to heat to the proper operating temperature. When the self-test is complete, the display will stabilize and show "000". Although the unit is now ready for operation, a 5-10 minute warm-up time is recommended before taking careful measurements.
5. Turn the *Voltage Adjust* control up to 200V and observe the bottom of the electron gun. The bluish beam will be travelling straight down to the envelope of the tube.

Note: Both the voltage and current outputs are controlled by an on-board microprocessor. Because the microprocessor automatically locks out the controls at both the minimum and maximum settings, there is no need to provide a manual "stop" on the knobs. When the knob reaches the maximum setting, it will still turn, although the value shown on the appropriate display will not change. These features prevent excessive voltage being applied to the tube. Coil current and beam acceleration voltage may be monitored using their respective monitor jacks on the rear of the housing. When not monitoring coil current, be sure the yellow jumper plug is installed in the current jacks. This circuit must be complete for current to reach the coils. Be aware that while monitoring current, some ammeters may automatically shut off after a specific period, breaking the circuit.

6. Turn the *Current Adjust* control up and observe the circular deflection of the beam. When the current is high enough, the beam will form a complete circle within the envelope. The diameter of the beam can be measured using the internal centimeter scale inside of the tube. The scale numbers fluoresce when struck by the electron beam.
7. For an accelerating voltage of 200V, measure the beam diameter for a series of coil current settings. Alternatively, determine the coil current necessary to bring the beam to each prescribed distance on the tube arm. If the mark falls between steps on the ammeter, interpolate the current. In general, best results are obtained at higher accelerations and coil currents.
8. Set the accelerating voltage to 300V, and repeat the measurements in Step 6.
9. Repeat Step 7 for additional accelerating voltages.
10. If a small ceramic magnet is available, move it close to the tube and observe the deflection of the beam. It is easy to see how properly designed

magnets can be used to focus and steer an electron beam.

11. When all of the data has been collected, switch off the apparatus.

If the electron gun is not pointed downward, the electron beam will travel on a spiral path. To correct this, loosen the mounting screws of the vacuum tube and rotate the tube a little until the electron gun is in the proper orientation and the beam is circular. This adjustment should be done by a laboratory technician before the laboratory session and not left to the student.

Data Reduction

From equation 3 it can be seen that the product of the electron path radius times the value of the magnetic field should be a constant for a single setting of the acceleration voltage V. From this average value, the value of e/m can be calculated.

Typical results are given in table 1.

Table 1

Accelerating voltage 300V. Beam diameter converted to meters. The magnetic field is in Teslas.

Coil Current A	Magnetic Field T	Diameter m	Radius m	Product r x B
2.9	2.26×10^{-3}	.05	.025	5.65×10^{-5}
2.4	1.87	.06	.03	5.61
2.1	1.64	.07	.035	5.73
1.8	1.40	.08	.04	5.61
1.6	1.25	.09	.045	5.61
1.4	1.09	.10	.05	5.46
1.3	1.01	.11	.055	5.58

Mean Value: $5.61 \pm .08$

From which

$$e/m = (-2 \times 300) / (5.61 \times 10^{-5})^2 = -1.91 \times 10^{11}$$

Your results will be different from those in the table. The tabulated values are just an example of the expected results. Similar calculations should be made for the other accelerating voltages and the overall value of e/m can be obtained. In exploring your data, you may notice that better results are obtained at higher accelerating voltages and coil currents. This is largely due to the imprecision of estimating beam position when it is more diffuse and/or at a larger diameter. If there is enough time, an analysis of errors in the experiment should be made so the accuracy of the final result can be estimated.

WRJB 09/1992
rev SM/RAS 03/2009

Specifications

Electron Tube

Diameter	130 mm
Gas	Low Pressure Helium
Electron Gun	Indirectly Heated cathode with accelerating anode
Life	300-500 hr, depending on usage

Helmholtz Coils

Coil Radius	147.5 mm
Coil separation	147.5 mm
Turns per Coil	132
Magnetic Field	0.79mT/A

Power Supplies

High Voltage	100-500 Vdc Regulated by internal microprocessor. Adjustable with front panel control. Monitor jacks on rear panel.
Coil Current	0-3.5 A Regulated by internal microprocessor. Adjustable with front panel control. Monitor jacks on rear panel.
Meters	2 Three digit LED panel meters
Controls power	Voltage adjust, Current adjust, switch
Protection	External line fuse, 3A Slo-blo (Do not exceed)
Dimensions	48.5 x 30.5 x 37.5 cm
Weight	6.8 kg