

## EA-75, EA-76 Precision Air Track

**Description:** Our Precision Air Track, a device with low friction, is used for kinematics experiments. Compressed air is injected into the cavity beneath the track. Since this cavity is sealed, the air can only escape through the small holes on the track itself. This provides a force strong enough to lift the gliders, which drastically lowers friction.



**Introduction:** Since it provides low friction, the Air Track can be used for a variety of mechanics experiments. The principles of friction less motion have been well understood for over 200 years, but it was not until the 1960's that the Air Track came into general usage. It allows an experimenter to quickly and easily simulate zero friction, which is very useful for collisions, acceleration due to gravity, energy transformation, projectile motion, and numerous other physical laws. Note: although the Air Track provides a very low coefficient of friction, some friction remains, as well as drag with the air itself. Because of this, experiments utilizing the Air Track will approach but not equal theoretical results. In addition, the Air Track contains the following accessories:

- Three (3) 100g aluminum gliders. These float above the Air Track.
- Eight (8) spring bumpers. Allow elastic collisions.
- Three (3) magnetic bumpers. Used for elastic collisions.
- Four (4) hook and loop bumpers. Used for inelastic collisions.
- Six (6) thumbscrews. Used for attaching accessories to the gliders.
- One (1) spool of thread. Used in conjunction with the pulley to study acceleration.
- Two (2) long springs. Used to join gliders together or to the end of the track.
- Two (2) short springs. Used to join gliders together or to the end of the track.
- One (1) weight hook. Used with thread and pulley.
- Four (4) 5g hanging weights. Used with weight hook.
- One (1) glider launcher. Used to launch gliders with repeatable force.
- Four (4) spring connecting brackets. Used to connect springs to gliders.
- One (1) low friction pulley. (Pully is pre installed onto the end of the Air Track)
- Twelve (12) 25g masses. Used to increase the mass of the gliders.
- Eight (8) photogate flags. Disrupts the beam of a photogate timer for measuring velocity.
- Eight (8) riser blocks. Turns the Air Track into an inclined plane.
- Two (2) photogate holders.

**Operation:** Your Air Track is almost fully assembled and ready to use. All that is left to be done is to connect the Air Track to an air supply, level the track, and adjust the air pressure. Note: you may wish to save the box the Air Track is shipped in. It is useful for storing your Air Track.

The Air Track will accept hoses 1 inch (25mm) in diameter. Should your hose be incompatible, wrap the end with rubber or pare down your hose until it fits. Due to the high pressure generated inside the Air Track, it is essential that your hose fit snugly in order to prevent leaks.

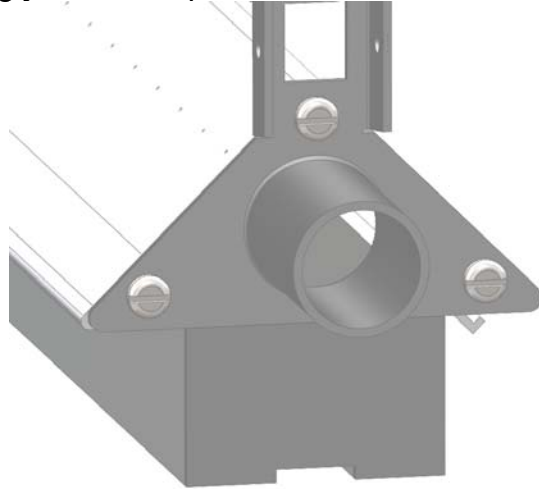

In order to level the Air Track, use the attached feet. For shipping purposes the feet are stored together; when you receive it, remove the center foot from the bar holding the other two. On the bottom of the Air Track you will find two threaded holes; one has a bolt in it. This bolt will be needed later. First, thread the single foot into its hole using the attached nut.

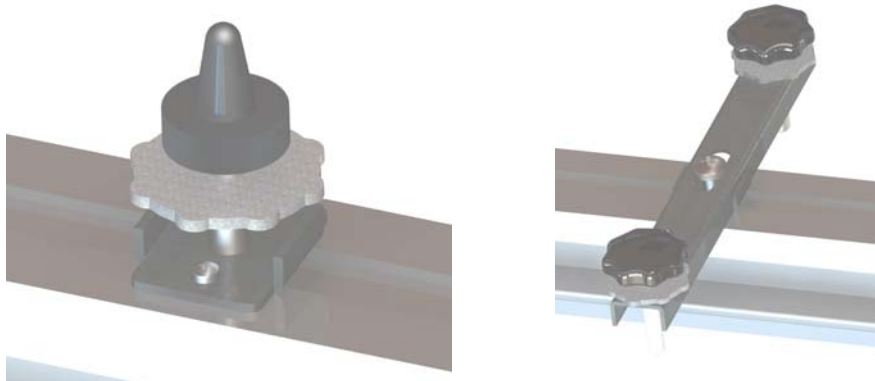

Second, remove the bolt from the second hole and use it to affix the bar containing the other two feet to the Air Track. The height of these feet is adjustable. This allows you to quickly and easily level your Air Track, regardless of the table or desk you are using.

The recommended air pressure for the Air Track is 0.25 PSI. This is the absolute minimum; to use this minimum pressure, the Air Track must be kept completely free of scratches and dirt. Often, it is better to use a pressure between 0.25 PSI and 0.5 PSI. Too much pressure will cause more air to escape near the inlet than elsewhere, which will cause turbulence and destabilize experiments.

It is not necessary to actually measure the amount of air pressure. A good way to test if the Air Track is leveled and the pressure is sufficient is simply to place one of the gliders on it and observe its behavior. If the glider floats gently above the track and shows no preference for the right or left end, your Air Track is ready to use. If the glider moves along the track of its own accord, the track is not level.

## HOW TO USE THE Air Track ACCESSORIES

### ***SPRINGS:***

There are two sizes and types of springs included with the Air Track. There are compression and extension springs.

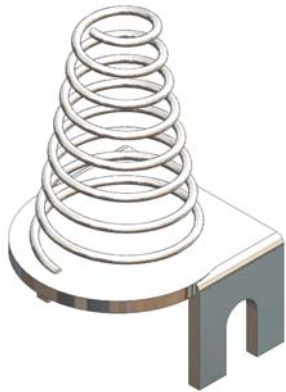

Compression Spring

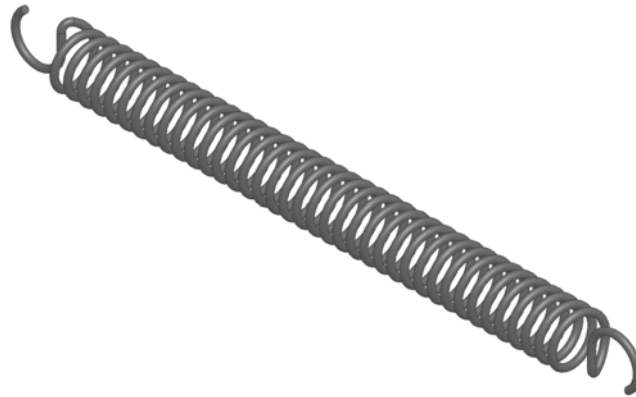

Extension Spring

The compression spring is used to cushion the gliders from impact to make collisions as gentle as possible. They are specifically designed for collisions at higher speeds. Their use results in a minimum loss of energy due to collision (we estimate errors of less than 5% per collision). The major loss of energy collision is transfer of momentum to the Air Track and table. Use of springs is essential, therefore, to keep this energy loss small. The compression spring is referred to as a "End bumper spring". The end bumper spring fastens either to the glider or to the Air Track itself also by means of the bracket. Simply slide the tab of the bracket into one of the holes on the end of the glider or track.

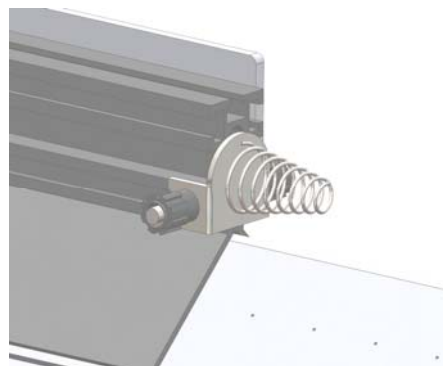

Installing the second pair of large bumper springs directly onto the glider results in collisions that are as gentle as possible under higher speeds.

The extension spring is used to attach a glider to a fixed point at the end of the Air Track. Various experiments can then be performed showing properties such as the spring constant.

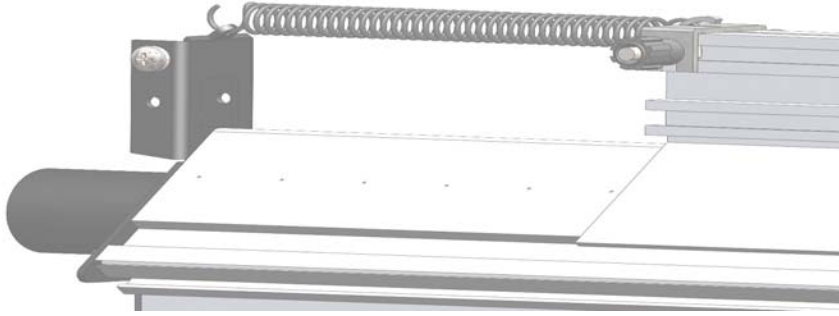

Care must be taken so that the track is adjusted so that it is very level in both the left-right and front-back directions. If the track is tilted the glider may drag against one side causing unwanted drag which will affect the results of the experiments.

### ***HOOK AND LOOP FASTENERS***

Two pieces of hook and loop to provide a quick, convenient, low-cost means of joining the two gliders together. These adhesive fabric fasteners are used for experiments with Zero-Rebound Collisions, where it is necessary to have colliding gliders adhere together and move as a unit. One piece of hook and loop fabric contains barbed fibers like hooks. The other contains a soft mat of random fibers. These hook and loop bumpers are placed on the Air Track gliders in the same fashion as the spring bumpers. Hold them in place with the included thumbscrews.

### ***PULLEYS:***

The Air Track comes with the end pulley pre-installed. You can pass the thread through the holes on the end bracket of the Air Track such that it drapes over the pulley. The weight hanger is attached to the end of the thread. The final setup should look like the diagram below:

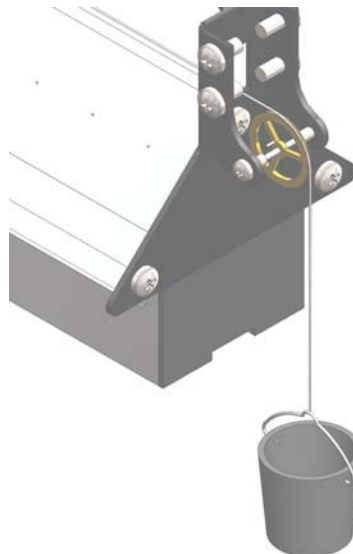

***WEIGHTS:***

The Air Track accessories also include a set of weights, both heavy and light. These weights can be attached directly to the top of the gliders in order to increase the mass of the gliders as might be required for an experiment, e.g. for successive iterations. Note that symmetric and even placement of the weights is essential to keep the glider perfectly balanced. The weights can be mounted in the upper slots, lower slots, or across the top of the glider. Placement depends on how much weight is required and if other accessories (end spring bumpers, photogate flags, etc.) will be used.

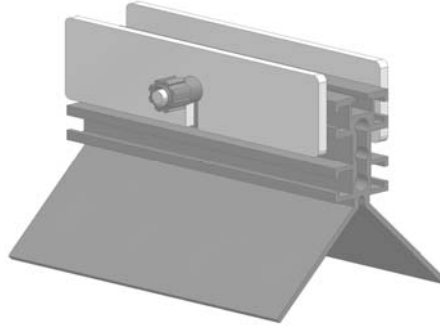
***PHOTOGATE LIGHT BLOCKING GATES:***

The photogate flags are attached to the top of the gliders for use with photogate timers. Eight flags of varying sizes are included.

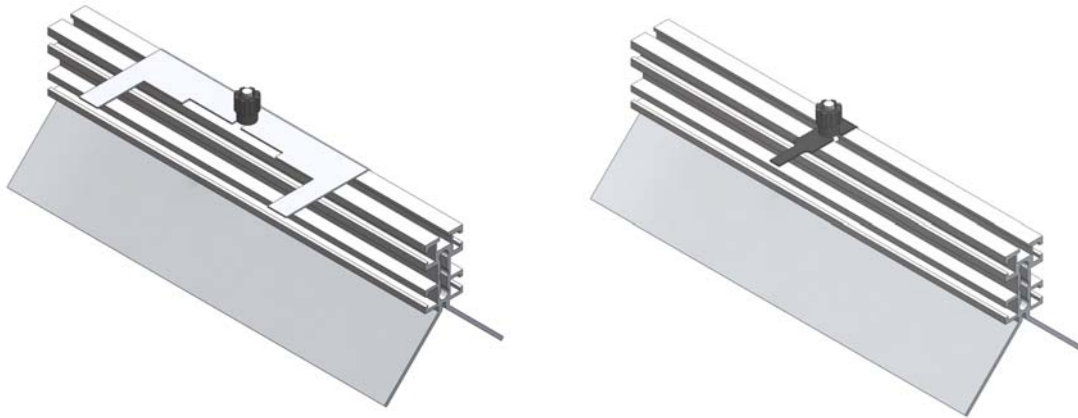
***HEELS AND LEVELING PADS:***

Included are also several round plastic disks used for setting the Air Track at an angle. They can be stacked for additional height. It is recommended to use a heel (piece with the indent in the center) directly under the single foot as it has been constructed to cradle the single leveling foot. Putting the Air Track on an angle will create an inclined plane for acceleration experiments.

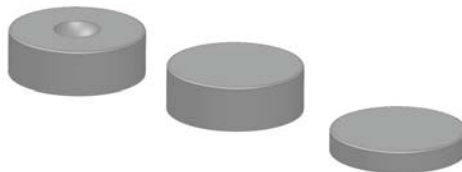

***MEASURING THE VELOCITY OF THE GLIDERS:***

There are multiple ways to do this. Some of the more convenient methods are listed below:

***PHOTO STROBE.***

This method uses motor strobe photography to take pictures in time. The time between pictures is known precisely. Since the end points - the points of origin and collisions - of the gliders is also known precisely (by reading these values off the metric scale), the velocity can be determined.

***SPARK TIMER:***

This method involves running paper tape alongside the metric scale. Its operation is similar to that of a tape timer. The gliders are hooked up to a source of high voltage power with a spark discharge at known intervals. Since the time between the discharges of sparks is known, the velocity can be determined.

***PHOTOGATE TIMER:***

In this method, the velocity of any moving object can be electrically timed by a timer. The timer measures the time it takes for the object to go through the photogate. Since both the distance traveled by the glider, and the time it takes to pass through the photogate is known, the velocity can be determined. This Air Track includes two photogate holders (arms) which have been manufactured to hold many versions of photogate timers on the market. The photogate arms are attached to the Air Track using the same thumbscrews used to hold the accessories to the gliders.

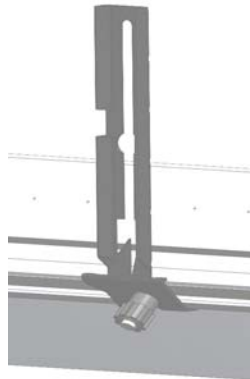
***COLLISIONS:***

**INELASTIC COLLISIONS:** The fraction of mechanical energy transformed into non-mechanical energy in a collision varies from 0 to 100%. A **PERFECTLY INELASTIC** collision involves the complete transformation of mechanical energy. There is zero rebound velocity after impact. An example of this would be a ball of wet clay dropped upon a hard, smooth surface. Any head-on collision where the colliding bodies lock together is perfectly inelastic. This is also referred to as a **ZERO REBOUND COLLISION**.

The only exception occurring naturally to the inevitable loss, or transformation, of energy during collisions is seen in the case of collision between some atomic and sub-atomic particles. This type of collision requires the conservation of kinetic energy. The particles do not come into physical contact in the conventional sense but interact instead through electrical and magnetic forces. These collisions are **PERFECTLY ELASTIC**. The example below shows no loss of kinetic energy:

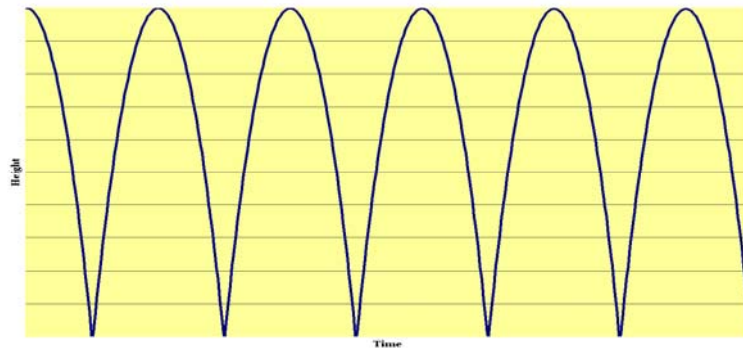

The next diagram graphically depicts a perfectly inelastic collision. It shows the rebound of a sphere with perfectly inelastic properties dropped onto a large, hard surface with zero rebound.



The final diagram represents a very common type of inelastic collision in which each successive rebound is less than the preceding one. In the example below, mechanical energy is transformed in each collision. This type of collision can also be called **MULTIPLE REBOUND**.

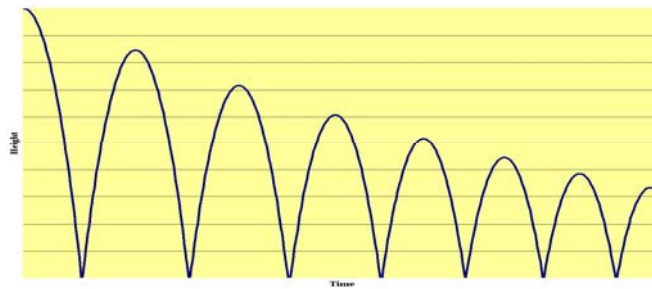

The Air Track can be used to study the theory described above. The fall and rebound of the colliding body occurs under conditions in which there is essentially a zero-resisting force between impacts. If an object were dropped directly onto a large-diameter hard surface, the resulting rebounds would be too fast to determine accurately the distances between each successive rebound without the use of very high speed photographic equipment.

**ELASTIC COLLISIONS:** The Air Track provides an almost friction less surface for determining the momentum of each glider both before and after collision.

The relative elasticity of different collisions can be demonstrated by attaching an end bumper spring to the end of the Air Track opposite the air inlet. Elevate the air-inlet side of the Air Track about 1.5 cm by means of the leveling pads, shims or a thin book. Release the glider from the top end of the track and read the rebound distances of the glider on successive rebounds by means of the attached Metric Scale. These distances will be proportional to the vertical height through which the glider falls.

We recommend assigning one student to read the positions and to call out the values to another student for recording.

Replace the end bumper spring with a different object, such as the launching cradle, or a set of polar opposite facing magnets (not included) and compare the results. Additional materials, such as a coiled steel spring, can also be substituted.

Change the angle of elevation of the Air Track and compare results.

A different approach to this experiment might be taken by using Nylon or Dacron thread, thread that melts (NOT cotton which burns) to hold a pair of magnetically repelling gliders together. A lighter is then used to melt the thread and the resulting displacement, velocities and accelerations of the gliders are observed.

**INELASTIC COLLISIONS (ZERO REBOUND):** In a collision of this type, much of the kinetic energy of the moving glider must be dissipated as it collides with a stationary glider. After collision the gliders must remain fastened securely together.

This therefore serves as a demonstration of the Law of Conservation of Momentum, which states that momentum is never created or destroyed. Whenever one body gains momentum, another body loses an equal amount; the total momentum of an isolated system of bodies remains constant.

To perform this experiment and keep the gliders fastened together, it is best to use the Velcro® bumpers.

Place both gliders on the horizontal Air Track and adjust the air pressure so the gliders move freely. Place one glider at the far end of the Air Track. Slide the second glider toward it so that the two gliders collide. Due to the mechanical catch, the gliders will adhere together and move as one unit after the collision occurs.

When the relative velocity of two colliding bodies is zero after the collision - in other words, if the objects stick together - this collision is termed perfectly inelastic. The linear momentum of this pair of colliding bodies is still conserved, but kinetic energy is not. Some kinetic energy is converted to other forms of energy in the process. The equation applying to this phenomenon is:

$$m_1v_1 + m_2v_2 = (m_1 + m_2)v$$

where

$v$  is the common final velocity

$m_1$  and  $m_2$  are the masses of the small and large glider, respectively.

To study the effects of zero rebound collisions, therefore, it is necessary to know the mass and velocity of each glider both before and after collision. The mass of each glider is known to be either 200 or 100 grams (weigh each of the gliders with all attachments for more accurate results). The velocity of each glider will have



to be measured both before and after impact. This is done using one of three methods, briefly described below.

### **ACCELERATED MOTION:**

Newton's Second Law of Motion states that:

$$f = ma$$

Two objects with unequal masses can be connected with a fixed pulley with negligible mass. This yields good results since the small frictional force of a pulley is generally constant.

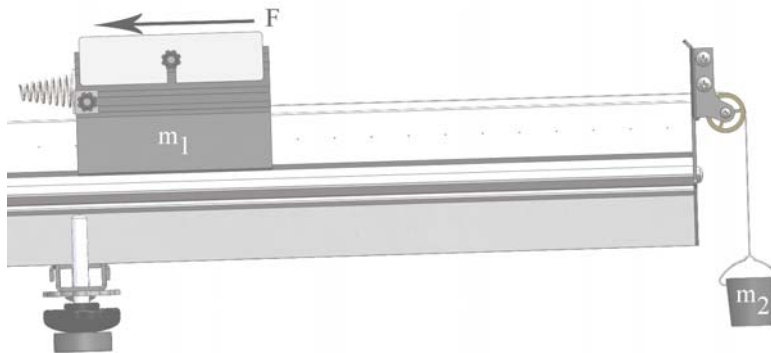

The diagram above depicts an Air Track used in inclined plane experiments to measure acceleration. The Air Track is ideal for this purpose, since virtually no resistance is offered to the relative motion of the sliding gliders. More conventional solid inclines have a variable frictional force. Acceleration can be determined mathematically by the following relationship:

$$a = \frac{(\Delta m)g}{(m_2 + \Delta m + m_1)}$$

Where:

a = magnitude of acceleration

m = extra weight (change in weight) - This is the weight that causes motion.

m<sub>2</sub> = large weight

m<sub>1</sub> = small weight (weight which counterbalances m<sub>2</sub>)

m<sub>1</sub> + Δm = Total weight of bucket plus contents

g = force of gravity

Thus the magnitude of acceleration can be determined by the use of two weights, m<sub>1</sub> and m<sub>2</sub>. m<sub>1</sub> is the lighter of the two masses which are tied to the opposite ends of a cord and hung over a fixed pulley. m<sub>1</sub> functions as a counterbalance to m<sub>2</sub> which is the heavier of the two. m is an additional mass which is added to m<sub>1</sub> to cause acceleration of the entire system. It is the change in mass that causes motion in the system. m<sub>1</sub> can be determined experimentally by finding out what value results in no acceleration up the incline. (Δm)g is therefore the full expression of the accelerating force. a (acceleration) is the same quantity for both m<sub>1</sub> and m<sub>2</sub> although it can act in different directions.

Acceleration can also be determined experimentally by measuring the time  $t$  required for the glider, starting from rest, to move a distance  $s$  along the incline of the Air Track.

Since acceleration is the rate of change in velocity, it can be expressed mathematically as:

$$a = \frac{\Delta v}{t}$$

Distance is expressed as:

$$s = \frac{1}{2}at_2^2 \quad (\text{where } v_0 = 0)$$

$v_0$  equals original speed. It is zero since the accelerating body is starting at rest.

Acceleration can therefore be computed by using the following equation:

$$a = \frac{2s}{t_2^2}$$

Theoretically, the values obtained for the acceleration of the glider under an accelerating force  $XX$  should be the same whether determining the change in mass or determining the distance covered during a specific lapse of time.

### **PROJECTILE MOTION:**

The Air Track can provide a virtually frictionless inclined plane ideal for accelerating a projectile. The horizontal and vertical components of the projectile can be determined, respectively, by measuring the location at which the projectile strikes the floor and the distance between the lower end of the Air Track and the floor. Based upon these values, the velocity of the projectile at the bottom of the incline can be computed.

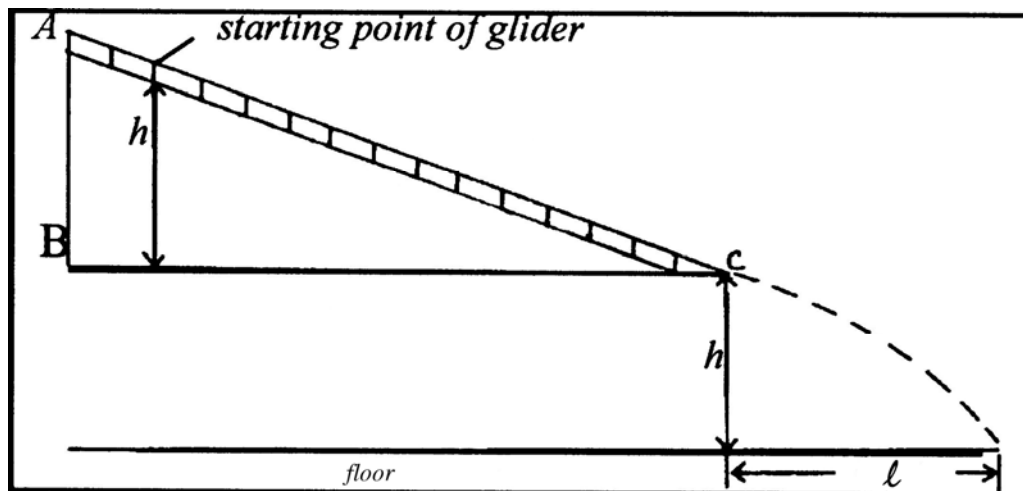

This diagram depicts the Air Track as used in projectile experiments. The frictional drag is a component in mathematical calculations when a conventional inclined plane is used. This is due to the infinitesimal, yet inevitable, surface regularities, which are enhanced by the great angle or length of the incline, required to

sufficiently accelerate the sliding object. In the case of the Air Track, however, the frictional drag is nearly zero and a very slight incline will suffice. Use a thin book, cardboard, or the included riser blocks to produce this angle.

The equation for computing the velocity of the projectile is:

$$mgh = \frac{1}{2}mv^2 \quad \text{or} \quad v = \sqrt{2gh}$$

Where:

m is the mass of the projectile,  
h is the height to the bottom of the incline and  
g is the force of gravity.

v is the velocity when the projectile reaches point C at the lower end of the incline, as depicted. The value for v as computed above is the magnitude of the velocity which would be attained by the free fall of a mass through the height h. Free fall describes a situation in which there is zero resisting force to the gravitational attraction of the earth.

### ***EXPERIMENTS IN ACCELERATION:***

#### ***Experiments in acceleration require the following materials:***

A SPACER of known thickness (a book may also be used)  
WEIGHTS  
PULLEY (included with this product)  
STRING  
SPRING SCALE  
STOP WATCH

First make sure your Air Track is level. Insert a SHIM or SPACER of known thickness T under the leveling screw in the end of the Air Track opposite the air inlet. The track now has an incline of T/87 where T is the thickness of the spacer in centimeters and 87 is the distance between the Air Track feet in centimeters.

Install the pulley assembly as described and tie a long STRING to the glider, passing it over the wheel of the pulley. Attach a sensitive SPRING SCALE or WEIGHTS to the free end of the string. This will allow the student to accurately weigh the loaded glider.

To compute acceleration a, apply the formula:

$$a = \frac{2s}{t^2}$$

where

s is the specified distance traveled by the glider  
t is the elapsed time.

Time readings  $t$  are necessarily of very short duration and can be made with a STOPWATCH with tenth-second graduations. These time readings must be made as carefully as possible for best results. Greater accuracy can be attained with a SPARK TIMER and spark sensitive paper.

### ***EXPERIMENT 1 – TESTING THE FRICTIONAL FORCE***

To study the effects of friction on acceleration, the glider should represent a weight only slightly less than the air pressure can support. Adjust the air pressure so that the glider just barely floats smoothly along the track. Test frictional force of your Air Track by placing the track in a horizontal position based upon sight alone. Position the glider on the track, apply air pressure and observe the motion of the glider. It will most likely accelerate. Raise the lower end of the track until the glider maintains the small initial velocity which is being applied. At this point the track is level.

The student can then experiment by elevating the track more to determine the thickness of the shims required for the glider to again accelerate. This information will help determine the amount of frictional force working against the glider.

**EXPERIMENT 2 - STUDYING THE ACTUAL HORIZONTAL FORCE**

The horizontal force of the entire system as represented by the Air Track can be symbolized by  $F_1$ .

It is depicted mathematically as:

$$F_1 = m_1 g \sin \theta = m_1 g \left( \frac{H}{L} \right)$$

Where

$\theta$  is the angle at which the Air Track is elevated.

$F_1$  may be measured with a sensitive spring scale or by applying weights to a string as shown in an earlier diagram.

The weight applied here should not be used to attain acceleration. Instead it should be used to determine the horizontal component of the gravitational force, or  $F_1$ . Once this force is determined, acceleration can be calculated by applying the relationship  $F = ma$

Set up your apparatus at sufficient elevation so your Air Track functions as an inclined plane. With the glider near the bottom of the incline, adjust the hanging load, by adding or removing weights, until the glider maintains its given small starting velocity as it moves up the track.  $F_1$  can be computed both geometrically (using  $m_1 g \sin \theta$ ) and experimentally (using  $m_1 g \left( \frac{H}{L} \right)$ ).

To determine the horizontal component of the gravitational force by experiment, weigh the loaded glider and measure the height H and length L of the Air Track.

**Computation of Drag:**

The film of air on which the gliders ride is a viscous fluid about 0.01 cm thick. It exerts a drag on moving surfaces that can be calculated as follows:

$$F = \frac{uAV}{t}$$

Where

F is drag force in dynes

u is viscosity of air,  $1.8 \times 10^{-4}$  poise

A is the area of glider surface in sq cm

V is velocity of glider in cm/sec t is film thickness in cm

Use of the large glider, with two 4.1 cm x 20 cm surfaces, yields:

$$F = \frac{(1.8 \times 10^{-4})(164)(v)}{0.01}$$

$$F = 2.95v$$

The drag is therefore 2.95 dynes for each unit of velocity. Since drag is proportional to velocity, low

velocities mean less friction.

The next consideration is the effect of drag on the velocity of the glider. Use the relationship:

$$F = m \frac{dv}{dt}$$

where

m is the mass of the glider (200 gr)

dv/dt is the deceleration.

This yields:

$$2.95v = 200 \frac{dv}{dt}$$

Solve for v in terms of t:

$$\frac{dv}{v} = \frac{2.95dt}{200}$$
$$\frac{dv}{v} = 0.0148dt$$

This means that velocity decreases 1.48 % each second.

Integrating the equation results in the following relationship:

$$\log_e \left( \frac{v_1}{v_2} \right) = 0.0148(t_1 - t_2)$$

Velocity can thus be shown to decay in half its original value in roughly 50 seconds.

## **Troubleshooting:**

### **Excessive drag:**

Low air pressure: increase blower speed; make sure air supply is clean.

Bent glider: file away nicks or projections. Use a vice to bend glider back.

Plugged holes: open with wire.

Tape, gum, or other material is adhering to the glider. Make sure it is clean.

Lint or dust under the glider. Make sure it is clean.

Bumpers are dragging on track.

Glider tilts sideways; bumpers are too high.

### **Bumpers work poorly:**

Metal to metal friction:

Spring is too high, tilts glider.

Spring is too low, drags on track.

Momentum is dissipated:

Use a rigid level table or surface

### **Track cannot be leveled:**

Uneven table: replace, or use shims under one end of the track.

Track is “high” in the center. See “Inherent Errors” section below.

### **Poor coupling in collision:**

Wobbling gliders: too much air pressure. Reduce blower speed or partially cover intake.

If you have other questions, please feel free to contact us. Our office hours are 8-4:30 EST. Contact information can be found at the bottom of the page.

### **Inherent errors due to Limitations in Manufacturing:**

Although the Air Track is theoretically supposed to provide a friction less surface upon which to perform experiments, this is not the case. There are a number of reasons for this.

Firstly, the gliders are supported by air. This layer of air is approximately 0.01cm thick, or about the thickness of a sheet of paper. This film is a viscous fluid, and as such it exerts a drag on moving surfaces. The drag can be determined mathematically. It is proportional to the velocity of the glider and has an effect of the velocity of the glider.

In theory, a glider resting on a viscous fluid should gradually slow down without ever coming to a

complete stop. In actuality, the glider oscillates around a position midway between the air holes. An Air Track with an infinite amount of air holes would eliminate this problem, but this exceeds current manufacturing methods and reasonable cost.

The thicker the film of air, the less the coefficient of friction will be. However, this advantage is outweighed by the increased instability of the glider.

Another potential fail point is the *straightness* of the Air Track. An ideal Air Track would have a very strong, large tube, a low weight to prevent sagging, a precision ground surface, and a nearly infinite number of holes. Carbon nanotubes might fulfill these requirements, but this technology is still in its infancy. Our Air Track is composed of aluminum, which does have a high strength to weight ratio. However, the tube is still heavy enough to sag slightly under the force of gravity. In addition, manufacturing limitations prevent the Air Track from having an error of less than one in 1000.

### **May we suggest:**

**611-1246 Air Supply for Air Tracks:** Our low noise air supply is perfect for Air Tracks or tables. It generates less than 60 decibels of noise, so it won't overpower your lecture. Compact design stows neatly under a table or lab bench. Includes tube, power cord, and on off switch. Consumes 300W. Blower speed is adjustable, with a maximum output of 6kPa.

**611-0103 Smart Photogate Timer:** Why pay more when this accurate and versatile timer does far more for far less? You can measure the time interval between two photo-gates, measure the time it takes to pass through one photogate, measure acceleration of a released ball, determine the acceleration due to gravity (with a picket fence), determine elastic and inelastic collision times, calculate cycles, determine the frequency of a rotating object, determine the period of a pendulum, and count time with great accuracy. Up to 20 data points can be saved.

### **Warranty and Parts:**

We replace all defective or missing parts free of charge. Additional replacement parts may be ordered toll-free. We accept MasterCard, Visa, checks and School P.O.s. All products warranted to be free from defect for 90 days. Does not apply to accident, misuse or normal wear and tear. Intended for children 13 years of age and up. This item is not a toy. It may contain lead or small parts that can be choking hazards. Adult supervision is required.