

# 615-4665 (10-205) Tesla Coil Instructions and Applications



**Science First**<sup>®</sup> would like to thank Robert Lichtenberg of Sugar City, Idaho for invaluable technical assistance with these instructions.

## Warranty/Replacement

### Parts:

We replace all defective parts free of charge. Additional replacement parts may be ordered by referring to part numbers above. We accept Master Card, Visa, American Express and purchase orders from educational institutions in good standing. All products warranted to be free from defect for 90 days. Does not apply to accident, misuse or normal wear and tear.

### Introduction:

The Tesla Coil is an air-core transformer with primary and secondary coils tuned to resonate. The primary and secondary function as a step-up transformer which converts relatively low-voltage high current to high-voltage low current at high frequencies.

The Tesla Coil demonstrates the fundamental principles of high frequency electrical phenomena. It shows the principles of ionization of gases and behavior of insulators and conductors when in contact with high frequency electrical fields.

Its inventor, Nikola Tesla, conceived it to be a means to transmit electrical power without wires. An antenna would pull the transmitted electrical energy into the electrical system. You can also consider it a simple radio transmitter. Operating within a broad range of high frequencies, which transmits power rather than information.

### Components:

The Tesla Coil consists of a vibrator or transformer, two high voltage capacitors, a primary, and a secondary connected to a ball terminal or antenna.

The vibrator is composed of an air slot core around which coils of copper are wound; and a buzzer which consists of two tungsten points or contacts which open and close by means of a spring as alternating current and electricity passes through the core and discharges in the spark gap.

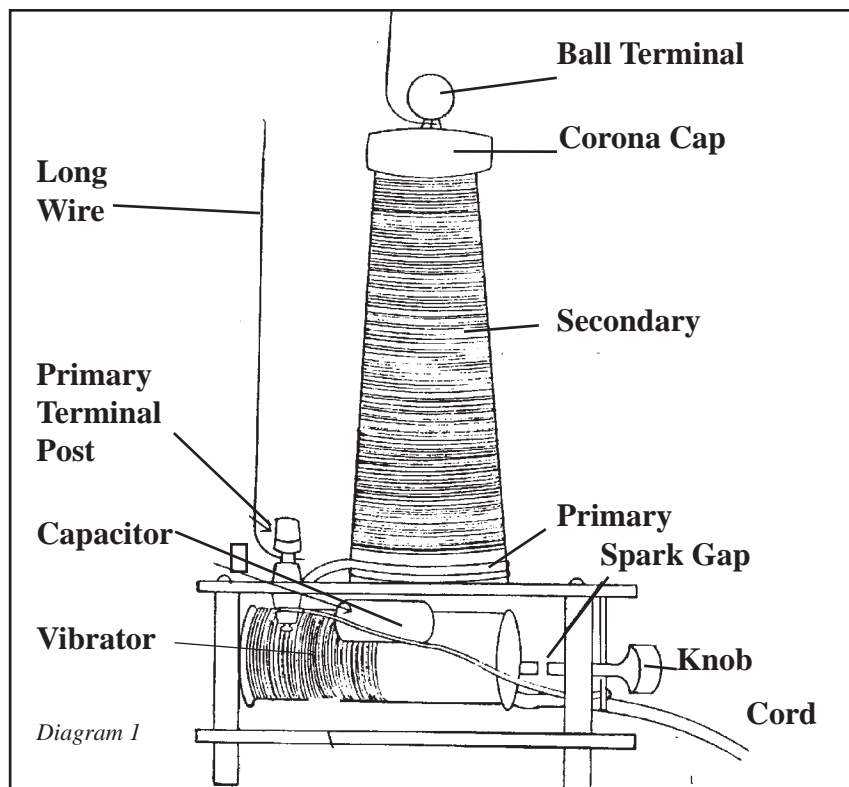

The capacitors are two large cylinders on either side of the spark gap. They are high voltage capacitors of a predetermined size and value.

The primary coil is a pair of thick insulated copper wires located next to, but not touching, the secondary and connected in series with the capacitors and spark gap.

The secondary is a cone-shaped coil (cone-shaped to keep the coil compact and for manufacturing reasons as less wire is needed) consisting of 400 turns of thin enameled copper wire. It functions as a transformer by stepping up voltage to high levels. The high voltage is given off by the terminal.

### How a Tesla Coil Works:

Refer to Diagram 2. When the plug is inserted into 110 AC current (220 volt for #10-206), electricity flows through the vibrator, an iron core with hollow center wound with coils of copper wire. This core becomes an electromagnet. The buzzer, 2 tungsten contacts opposite each other, not quite touching, pulls apart when the electromagnet is activated

and closes when the magnetic field decays. This occurs 120 times per second - each time the AC current changes polarity of the electromagnet.

The capacitors charge up when the buzzer contacts are open, since the current passes into them to complete the electrical circuit. When the contacts are closed, the capacitors are shorted together and current does not pass into them. The open contacts allow the air in the spark gap - the small space between open contacts to ionize, which permits a discharge that short circuits the transformer and capacitors. But the capacitors retain their electric charge, since the function of a capacitor is to store an electrical charge and thus provide energy to create an electromagnetic field.

This spark taking place in this spark gap does not consist simply of a single spark passing in one direction, as would appear to the eye, but a number of separate sparks passing back and forth in opposite directions. They take place so rapidly you cannot see the direction change. The time during which the spark appears to

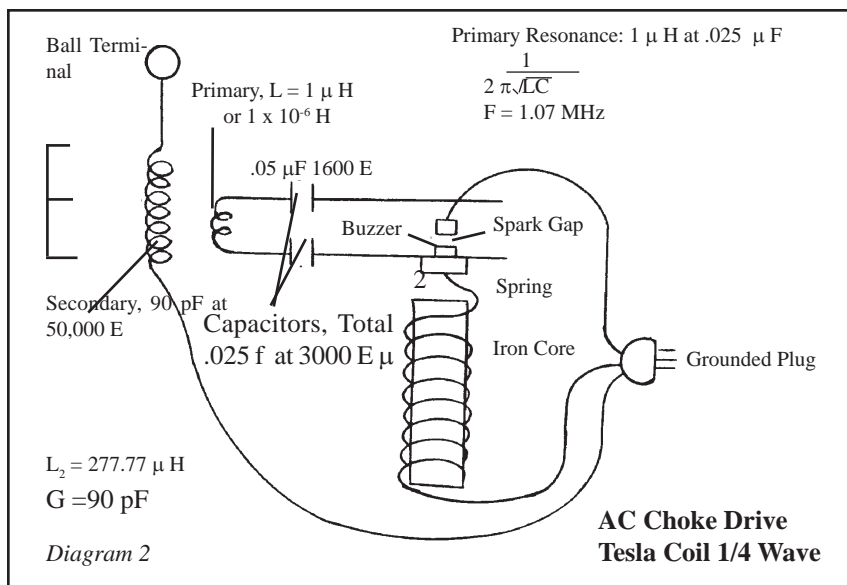

pass may only be a fraction of a second, but during that time the current may have oscillated back and forth several thousand times.

The electromagnetic field is formed by the primary which converts the charge stored in the capacitors to magnetic energy. The electrical charge is transferred to the primary by the capacitors when the magnetic field in the iron core decays. When the magnetic field in the iron core is reactivated, the field generated in the primary is the one to decay, and the electrical charge is transferred back to the capacitors with every half cycle, a charge of increasingly higher voltage as each activation of the magnetic field adds to the charges previously generated.

The vibrator also acts as an air core transformer, boosting the voltage to medium high levels with every half-cycle pulse of AC current. The high frequencies produced are rich in harmonics since each pulse of electricity across the spark gap is composed of many surges of electrical energy.

The capacitors in this Coil have a particular size and value. They serve the dual function of storing electric charge and filtering through the high frequency component of electrical current while blocking low frequency 60 cycle current. This is a safety feature, since by isolating the primary

from the 60 cycle component of the current, the electrical circuit will not be complete in regard to the 60 cycle component and you will not receive a shock if you touch the coil directly. Another safety feature is the fact that an air-core transformer by its nature does not pass 60 cycle current well.

The result is that high frequency electrical energy is built up by the generation and decay of the magnetic field in the primary every halfcycle, often reaching many million cycles per second.

When the high frequency is great enough and reaches the voltage predetermined by the size and value of the capacitor, the primary induces a magnetic field in the secondary. Inducing means a moving magnetic field causes a magnetic field to form in another wire coil located close to, or inside, the first coil.

The primary consists of two thick insulated copper wires which are resonated by the capacitors to equal the natural resonant frequency of the secondary. When the resonance equals that of the secondary, a magnetic field is formed in the secondary. Resonance may be compared to a cymbal: when a cymbal of a certain size and weight is struck, it rings at a specific frequency. In the Tesla Coil, the right capacitors and secondary

“ring” at the chosen high frequency.

Resonance may also be compared to a swing. When inductive impedance and capacitive impedance of a circuit are equal, the electricity oscillates back and forth between inductive component (primary) and capacitive component (capacitors, also called condensers). When pushing a swing, a person can cause large forward and backward motions with small pushes administered at the correct frequency. Applying energy at correct frequencies builds up high potentials in a resonant circuit.

A person in a swing weighing 200 pounds may be pushed by a small child about 50 pounds who may push with only one pound of force. If he times his pushes to coincide with the direction of the swing and keeps adding a pound of force each time, he will eventually have to stop to avoid hurling the person in the swing out into space.

An analogy used by inventor Nikola Tesla himself is to picture a wine glass broken by a violinist’s note. The glass is shattered because the vibrations happen to be the same frequency as the vibrations of the glass.

Since at the right resonant frequency, the AC resistance, or reactive impedance, is zero with the right coil and capacitor, and now the maximum current can flow according to formula:

$$\frac{1}{1/2 \pi \sqrt{LC}} = Fr$$

The secondary, like the vibrator, functions independently as a step-up transformer of about 3,000 volts. Since it has many more coil turns of copper wire in its secondary from the primary voltage of 110 volts of AC input, then electrical energy is supplied.

As the electrical energy from the vibrator is fed to the capacitors of the primary air core transformer and coil at its base, it now creates another independent circuit of the vibrator type transformer. The vibrator secondary output of 3,000 v is applied to this primary circuit, known as the air core

tesla resonant transformer (oscillator).

Its energy is then induced to the cone shaped coil with the ball on top. It is the number of turns known as inductance and its self-capacitance. When the primary supply is properly tuned to the secondary, a high voltage, high frequency output is developed of about 50,000 volts.

In this case, this unit's total primary capacitance is .025 microfarads at 3,000 volts and its secondary capacitance is 90 picofarads at 50,000 volts. It is the square root of the primary to the secondary capacitance that determines the approximate output voltage of 50,000 volts, according to the following formula:

$$\sqrt{\frac{C_p}{C_s}} \text{ or } \sqrt{\frac{.025 \mu\text{F}}{90 \text{ pF}}} \text{ or } \sqrt{\frac{25 \times 10^{-6}}{90 \times 10^{-12}}}$$

= Total  $\sqrt{277.77}$   
 = **16.66 x 3000 volt vibrator secondary**

With the current at maximum resonance, a high voltage, high frequency of one million impulses are produced at the ball of the secondary.

The Tesla transformer does not function on turn ratio windings. It functions instead on the ratio of the primary capacitance to the secondary capacitance.

The secondary, like the vibrator, functions as a transformer. Since it has more coils of wire than the primary, it boosts the high voltage.

The secondary is a cone-shaped coil located next to but not inside the primary. Only the first few turns are within the electromagnetic field created by the primary. Only a small difference in voltage exists between each turn of the coil and the one preceding it. This low voltage differential per turn prevents voltage from breaking down copper wire insulation and short circuiting the secondary.

The secondary produces a current called high frequency electricity. High frequency currents reverse their flow, or alternate, from 100,000 to one million times a second.

### How To Operate:

Use Tesla Coil on bench or table with nonmetallic surface to rule out danger of electric shock. Plug into grounded outlet supplying 110 volt 60 cycle current (in case of **10-206** Tesla Coil, 220 volt electricity). Voltage of household current may vary slightly. Turn black knob on vibrator until a buzzing sound is heard.

**Q:** How do capacitors filter through the high frequency component of the electrical current while blocking the low frequency 60 cycle current?

**A:** Capacitors pass AC much better than DC. Capacitors are arranged as a high-pass filter placed in series with the primary. At 60 Hz, this is nearly an open circuit. At 1 megahertz, though, the capacitor puts very little reactance into the circuit.

$$X_c = \frac{1}{2\pi fc}$$

where  $X_c$  is capacitive reactance,  $f$  is frequency,  $c$  is capacitance. So as frequency increases,  $X_c$  gets smaller.

### Adjust with Discharge Wand:

The discharge electrode is a large hooked metal rod. Its uncurved end is placed in the hole in the top of the primary terminal post - a black knob protruding from the plastic base. When you plug in your Coil, discharges will pass between the ball terminal and the tip of the discharge electrode. Long, intense discharges mean maximum output.

The discharges can be seen from a distance, making this a good class demonstration.

### Additional Materials Needed:

*Some experiments that follow require one or more additional materials.*

**One 100-200 watt clear glass incandescent light bulb, nitrogen filled. Standard 100-200 watt light bulb. The higher the wattage, the more visible the results. A frosted bulb will work with less visible results.**

**Fluorescent lamp tube. Any size, 40 watt standard recommended.**

**One 2 to 3 volt miniature screw-base flashlight bulb**

**Miniature screw-base lamp socket**

**Aluminum foil**

**4 foot length of 20 gauge, plastic**

**stranded wire.** This is included in your accessory kit. Cut into 1 ft. and 3 ft. lengths.

**Uninsulated copper wire.** Also included. Cut wire into lengths required in the following experiments.

### Adjusting for Peak Performance:

*For best results, adjust your Coil for proper operation.*

- 1. While machine is unplugged, fasten wire to ball terminal.** Take small piece of thin bare wire provided and fasten underneath ball terminal by winding it around the screw tip to which ball terminal is attached. Point free end upward.
- 2. Plug in Coil.** Plug into ordinary 110 volt household outlet (for **10-206**, 220 volt). Light streamers will issue from the tip of the wire, since the wire's sharp end will break down the surrounding air more easily than will the ball terminal.
- Adjust buzzer knob until longest possible streamers emanate from wire end. Long streamers indicate circuit of primary and secondary coils are resonated. In this condition your machine operates at maximum efficiency.
- It may be necessary to readjust the buzzer knob during operation as the unit warms up. This is normal.

### How To Handle High Frequency High Voltage Electricity Safely:

The electricity generated by the Tesla Coil does not pass through your body. It flows harmless over your skin.

High-frequency currents possess unusual properties. Since they travel only on the surface of wires and conductors, a hollow tube conducts this type of current as well as a solid rod of the same diameter. High frequency currents do not cause a shock. You can take a piece of metal, approach a high frequency coil and throw a spark 2 to 3 feet long without any sensation

except slight warmth.

However, while high frequency high voltage electricity will not produce a shock, it can cause a burn at one small point of contact. This is because the output is concentrated in a small area (the vicinity of the ball terminal) forming an electrical arc that becomes intensely hot.

This concentration of current may be broken down by discharging the coil with a small piece of metal held close to the ball terminal. We suggest a coin, knife or piece of bare wire. As you approach holding this item, you increase the area of contact and reduce the current per unit of area, which will not cause a burn.

You can also move your finger quickly so that it does not remain in the same position with relation to the ball terminal. This results in a safe flow of high frequency high voltage electricity over your skin.

Low frequency currents, either AC or DC, do not possess this ability. They pass through the body directly (specifically through the liquid-filled tissues). A voltage that can produce serious injury in the form of low frequency AC or DC will flow over the surface of your skin if it is in the form of high frequency electricity.

The longest possible light streamers indicate the circuit of the primary and secondary coils are resonated. In this resonated condition your machine operates at maximum efficiency.

## Experiments

### **Experiment 1:** **Discharging**

*You Need:*

- Piece of metal (coin, key, bare uninsulated wire etc.)

Hold a small piece of metal in one hand. Plug in Tesla Coil and approach ball terminal with metal. The high frequency high voltage electrical discharge forms an arc between ball terminal and a metal object. See how far out you can draw an arc.

### **Experiment 2:** **How a Conductor Affects the Flow of High Frequency High Voltage Currents**

*You Need:*

- Short length of bare wire

With the ball terminal in place, plug in your Coil. Examine ball terminal to see if there are any signs of an electrical discharge issuing from it.

The ball terminal, being metal, is a conductor. However, there will normally be no such discharges, since the smooth rounded surface of the ball causes a uniform stress on the surrounding air.

Operate the Coil in a darkened room.

Examine the ball terminal. (If the Coil is adjusted properly it may break down the surrounding air despite the smooth, round shape of the ball terminal. Any such discharge will be most noticeable in the dark.)

Unplug the Coil and unscrew the ball terminal from its top.

Take a short length of thin, bare wire, preferably pointed at one end.

Fasten wire to the screw end from which the ball terminal has been removed, with pointed end of wire bent upward.

Plug in Coil and note profuse discharge that issues from the sharp bare point. This type of discharge is known as Corona Discharge.

This experiment illustrates the fact that high frequency high voltage electricity issues more readily from a conductor with sharp points than a conductor with smooth round surfaces. (This is the reason that sharp bends, pointed projections and sharp corners are avoided in wiring high frequency equipment.)

A practical example of this principle is the way high voltage metal enclosures of televisions are wired.

### **Experiment 3:** **How Insulators Behave at High Frequency**

*You Need:*

- 100-200 watt clear glass light bulb
- Special lamp socket, included
- Piece of metal
- Other insulators (wood, plastic)

With the Coil unplugged, the remove ball terminal from top of Coil.

Screw the special lamp socket on exposed threaded stud.

Mount the light bulb onto lamp socket by screwing it on.

Plug in the Coil, place your finger tip on top of the glass light bulb and move it quickly over surface of bulb.

Observe the discharges which take place in the bulb and lightning-like feelers that reach out from the bulb's electrodes to a point on the inner surface of the bulb directly beneath your finger.

Take piece of metal and touch bulb with it. Observe difference in appearance of discharges.

Although the high frequency currents from the Tesla Coil pass through the glass of the light bulb and into your finger tip, you receive no physical sensation. The reasons are: one, high frequency currents flow over the surface of the skin; two, the total current is distributed over the entire area of your finger tip which is in direct contact with the glass.

Remember to keep your finger moving quickly. You may get a burn if you concentrate the discharge at a single point on your finger.

This experiment shows that glass, an excellent insulator for medium and low frequency currents, is readily broken down by high frequency high voltage electricity. Test the insulating properties of other materials.

Remove the light bulb and special lamp socket and return ball terminal to the top of the Coil.

Hold wood, plastic or paper in direct contact with the ball terminal with one hand while trying to draw a discharge through the insulating material to a piece of metal in your other hand.

### **Experiment 4:** **Ionizing Gases by Electrical Stress**

*You Need:*

- Fluorescent lamp tube, 40 watt
- Neon lamp. Included
- Short length of bare wire

While the Tesla Coil is not in operation, attach the neon lamp to the ball terminal. The neon lamp is a very small light bulb (N E<sub>2</sub>) with two thin copper wires protruding.

Use one of the thin wires to attach lamp to ball terminal. Wind the wire around screw stud onto which the ball terminal is mounted.

Plug in the Coil and watch how brightly the neon lamp lights up despite the fact that it is connected to the Tesla Coil by only one wire.

With the short length of bare wire (NOT your hand) touch the glass bulb of the neon tube. Watch how the red-orange discharge becomes even brighter and more concentrated. Not only do the electrodes in the neon lamp glow - the entire bulb exhibits a red-orange glow.

Unplug the Tesla Coil. Remove neon lamp from ball terminal. Plug in the Tesla Coil and approach ball terminal holding fluorescent light bulb in your hand.

Note the difference in color of the fluorescent light bulb compared to the neon lamp.

The glow appearing in both lamps is caused by ionization. Ionization occurs when 2 atoms collide, splitting off one or more electrons and giving off energy in the form of light. Every gas will produce its own characteristic color when it becomes **ionized**.

When the gases in the neon and fluorescent tubes are subjected to high electrical stress at low pressure. Their atoms are excited and give off characteristic glows. In the neon tube, neon gas is excited; in the fluorescent tube, mercury vapor and argon gas.

### **Experiment 5:** **How Pressure Affects Ionization of Gases**

*You Need:*

- 100-200 watt clear glass light bulb

Operate your Coil with the ball terminal in place. Hold bulb by its glass, not touching metallic base). Bring the base of the bulb slowly toward the ball terminal. Stop at the point where the gas in the bulb begins to ionize.

Observe the distance between the ball terminal and the point at which the bulb begins to glow. The gas contained in the bulb ionizes at the same distance from the Coil even though the electrical stress at this point is much less than it is at the ball terminal's surface.

Observe that although the gas inside is ionized, the gases in the surrounding air are not. In fact, the gases in the atmosphere do not ionize even when they are in contact with the ball terminal, where the electrostatic stress is greatest.

The gas usually used in high wattage incandescent light bulbs is nitrogen, a small amount of which is introduced into what is otherwise a vacuum inside the bulb to prevent the filament from growing brittle. The nitrogen is therefore at very low pressure inside the bulb.

This experiment shows that a gas at low or reduced pressure, such as the nitrogen in the evacuated light bulb, will ionize more easily than the same gas at atmospheric pressure.

### **Experiment 6:** **How Gases Differ in the Ease With Which They Ionize**

*You Need.*

- One fluorescent tube, any size
- One 100-200 watt clear glass light bulb
- Neon lamp (included)

Certain rare gases, such as neon, argon, xenon, krypton and helium, will ionize more readily than others due to their atomic structure.

This is demonstrated using a stan-

dard high wattage light bulb (containing nitrogen gas), a fluorescent tube (containing a combination of mercury vapor and argon), and a neon lamp (containing neon).

Hold each bulb by the glass itself, not touching the metal base. Bring each bulb in turn toward the ball terminal while the Coil is operating. Stop when the gas in each bulb ionizes.

Compare the distances from the ball at which the three gases ionize.

The standard high-wattage light bulb must be brought much closer to the ball terminal before its gas ionizes. Therefore nitrogen must be brought into an area of greater electrical stress than either neon or a combination of argon and mercury vapor before it breaks down.

### **Experiment 7:** **Sparking Potential**

*You Need.*

- About 7 inches of stiff bare wire (included - cut to desired size)

While the Coil is unplugged, connect one end of length of stiff bare copper wire to the primary terminal post, a plastic knob protruding from the base.

Connect the wire to the terminal post by bending one end of the wire into a U shape. Place this bend into the banana jack on the base of the unit. Make sure the wire is held securely in position, with its free end projecting up into the air. Operate Tesla Coil and move free end of wire toward terminal by hand. Stop at point where a spark jumps from free end of wire and terminal.

The distance between the free end of wire and the ball terminal represents the distance over which the electrical stress generated by the Coil breaks down, or ionizes, the air. The amount of electrical stress needed to create a spark is called the SPARKING POTENTIAL. For normal dry air, the sparking potential is 30,000 v per cm.

By measuring the distance between the free end of wire and the surface of the terminal, and by assuming that the sparking potential between the two is 30,000 volts per centimeter, you can estimate the sparking potential that exists between the wire and terminal.

### **Experiment 8:** **How High Voltage Power is Transmitted**

*You Need:*

- 2 lengths of bare copper wire, about 12" and 7" in length (included. Cut to length)

Fasten 12" length of bare copper wire to ball terminal of the Coil by winding it around screw stud onto which the ball terminal is secured.

Fasten 7" length of bare copper wire to the primary post as before.

Position two wires in a vertical direction, parallel to each other and 1- 1/2 inches apart. This simulates a high voltage power transmission line, in which two wires are spaced widely.

Operate the Coil and observe the ionization that occurs. (This is best if performed in a dark room.)

Note how ionization is confined to a zone surrounding the two lengths of wire, and how it takes the form of a visible corona discharge.

Gradually decrease the distance between the two wires until the point is reached where the air breaks down or sparks. Observe the effect that decreasing the spacing of the wires has on the corona discharge.

High voltage transmission lines work in a similar way. Two lines far apart run parallel to each other. When the air surrounding the wires of a high voltage transmission line becomes ionized, the ionization is confined to a zone around both wires and produces a discharge in the air called a corona.

**The distance between the two wires is crucial: it must be far enough so that sparking between does not occur.**

Replace the ball terminal with a special socket. Insert a 100-200 watt clear glass bulb into the lamp socket.

### **Experiment 9:** **High Frequency High Voltage Electricity**

*You Need:*

- One 100-200 watt clear light bulb
- 12 inch length of plastic stranded wire (included)
- Special lamp socket (included)

Operate the Tesla Coil and adjust for maximum output as follows: turn buzzer knob **counterclockwise** (facing Coil with buzzer on your right) until buzzer just stops working. Slowly turn buzzer knob clockwise and observe changes occurring in light bulb. (The Tesla Coil is accurately adjusted as it leaves the factory. You will be able to determine the point at which it just begins operation by first turning the knob counterclockwise.)

The discharges taking place inside the light bulb have differing characteristics. At one setting, they resemble slow-rising, smoke-like streamers. At another setting, they take the form of miniature bluish-colored lightning bolts.

At a third setting, you observe quick, erratically moving little points of bluish flame travelling up and down the wires inside the lamp

Brush discharges produced by high frequency electricity are more pronounced in a gas at reduced pressure (as in low-pressure nitrogen inside light bulb) than in air.

Remove the special lamp socket from top of the Coil. Strip insulation off both ends of 12-inch piece of plastic stranded wire to a length of about one inch. Fasten one end of wire to screw stud from which lamp socket has been removed, with other end protruding upward in vertical direction. Fan out individual strands of free end of stranded wire so they are arranged like a comb.

Operate the Coil at different settings of buzzer contacts (as above). Observe the types of brush discharges that result.

### **Experiment 10** **Transmitting High Frequency Electricity Over A Single Conductor**

*You Need:*

- Special lamp socket (included)
- One 100-200 watt clear glass bulb
- One 3 foot length of plastic 20 gauge stranded wire (- cut to size)
- One 8/32 screw
- Glass or plastic tumbler

Cut 3-foot length off 4-foot plastic stranded wire. Strip insulation off both ends to a length of about 1/2 inches.

With ball terminal in place, fasten one end of wire to screw stud onto which terminal is mounted. Connect other end of wire to base of lamp socket. Do this by winding wire around threaded spacer at base of socket and fastening on screw to hold wire in place.

Stretch wire out to full length between light bulb and Coil so it has no contact with other objects.

Install high-wattage tight bulb in lamp socket. Insert bulb inside glass. The reason for this is that the light bulb must be insulated from table or bench on which Coil is placed.

Operate Tesla Coil. Observe how high frequency electricity is carried by single wire (with no second wire to serve as return path) to light bulb. Once reaching bulb, the high frequency high voltage electrical currents stream out from its filaments to ionize gas inside bulb. From there they pass into the surrounding air and eventually back to the Coil

This experiment illustrates how air is used as the return path between light bulb and the Tesla Coil where no second wire exists to serve as return path.

### **Experiment 11:** **Demonstrating the Two Components of High-Frequency Electrical Fields**

*You Need:*

- 12" stranded wire (included)
- One 2 -3 v screw-base flashlight bulb
- One fluorescent tube, any size
- Radiating plate, any (included)

Unplug the Coil and remove the ball terminal. Fasten radiating antenna plate to screw stud by placing small hole in bent "L" of plate over stud. The bulk of plate will project upward vertically. Secure plate by screwing ball terminal back onto screw stud.

Plug in the Coil. Hold base of fluorescent tube and approach radiating antenna plate. When you reach point where gas in tube ionizes, slowly move tube away. Observe how the gas in tube, once ionized, remains ionized even when the tube is moved away to point where the electrostatic stress is much lower than required to produce ionization in the first place.

The two components of high frequency electrical fields are: an electrostatic radiation field and an electromagnetic induction field.

This experiment demonstrates the effect of the electrostatic radiation field. Its electrostatic stress is insufficient to initiate ionization (shown by bringing the tube close to the Coil to cause it to glow) but is sufficient to maintain ionization in a gas at reduced pressure (shown when you moved the tube away). The radiation field can ionize a gas but cannot light the filament in a lamp.

Remove antenna plate. Take 12" length of wire, strip 1/2" insulation from both ends, and form a single-turn loop 3 -3 -1/2 inches in diameter. When Coil is unplugged, arrange loop around corona cap near top, beneath ball terminal.

Fasten ends of plastic wire (scraped free of insulation) to each screw terminal of flashlight lamp socket by winding each wire end around each screw terminal. Insert a

2 to 3 volt screw-base flashlight lamp into the socket fastened to top of the Coil. Operate the Coil.

The flashlight lamp is short-circuited by this wire loop. No electrical energy can come from the electrostatic radiating field. The field is weak, which can maintain but not initiate ionization. And yet the flashlight lamp glows brightly. The energy for this must come from the electromagnetic induction field generated by the Tesla Coil.

### **Experiment 12:** **How Faraday Shields Affect Electrostatic Radiation**

*You Need:*

- 12" square piece of metal foil
- Neon lamp (included)
- Make a simple Faraday Shield by cutting slots in the metal foil to resemble comblike teeth. (*Diag. 3*)

A Faraday Shield is a network of parallel wires connected to a common conductor at one end, like a comb. The common conductor is grounded. It provides electrostatic shielding for the electromagnetic component.

With the ball terminal in place, operate the Coil. Hold neon lamp by glass bulb and bring toward ball terminal until neon gas ionizes. Stop at this point. With the Faraday Shield in your other hand, lower it slowly between terminal and lamp. (Holding the shield provides the ground needed for high frequency currents.)

*Diagram 3*



Observe how the neon lamp deionizes or stops glowing when Faraday Shield is between lamp and Coil. Bring neon lamp closer to ball terminal and repeat procedure. This shows how a simple Faraday Shield can cut off the electrostatic radiation field from the Tesla Coil.

### **Experiment 13:** **How an Insulated Conductor Affects an Electrostatic Field**

*You Need:*

- One Neon lamp (included).
- Small radiating plate tied with piece of string or rubber band

Tie a piece of string through the hole at one end of the small plate or loop a long rubber band. (This insulates the radiating plate from direct contact with your hand.)

With ball terminal in place, operate the Coil. Hold the neon lamp by its bulb and bring toward the ball terminal. Stop at the point at which the neon gas in the lamp ionizes.

Withdraw the lamp to a position just beyond that in which neon gas deionizes or ceases to glow.

While continuing to hold the lamp in this position, pick up the string or rubber band attached to small plate with your other hand. Bring the suspended plate toward the neon lamp until it touches one of lamp terminals (one of the thin wires protruding from the base).

Observe how neon lamp ionizes when insulated conductor (the plate) touches one terminal.

Break contact with the conductor by removing the plate. Observe that lamp stops glowing.

This experiment shows the effect of an insulated electrical conductor on an electrostatic field. Introducing an insulated conductor alters the electrostatic stress distribution by concentrating stress around the conductor. The conductor will then ionize lamp when lamp is located at greater distance from ball terminal than distance required to ionize lamp in the first place.

### **Experiment 14:** **Stress Distribution on Insulated Conductor in Electrostatic Field**

*You Need:*

- Neon lamp (included)
- Small radiating plate
- String or rubber band



Suspend the plate from string or a rubber band as above. Holding the lamp by its bulb, bring it toward the ball terminal, stop at the point at which the neon gas ionizes. Withdraw the lamp just beyond the point where the neon gas stops glowing.

Hold the plate in your other hand by means of an attached string or rubber band. Approach the lamp from the opposite side with the lamp between the plate and ball terminal. Touch one terminal of the lamp with the plate. Watch the lamp glow when the insulated conductor - the plate - touches one terminal, despite the fact that the lamp is too far away from ball terminal to ionize on its own.

Radio and TV antennas operate this way. They serve as insulated conductors to intercept high frequency broadcasts from radio and TV transmitters.

### **Experiment 15: Transmitting Electrical Power Through Space without Wires**

*You Need:*

- One 2.3 volt flashlight bulb
- Miniature screw-base lamp socket
- Piece of string or rubber band
- Small and large plates
- 2 lengths of plastic insulated wire, 18" each (included)

Cut 3 foot length of wire (used in **Experiment 10**) in half, yielding two 18" sections. Strip insulation 1/2" from both ends of both pieces. Remove ball terminal and mount either small or large plate vertically on threaded stud. Fasten by screwing terminal onto stud.

Connect one end of one wire length to "primary terminal post" by inserting bare end of wire through small hole located between two black plastic portions of primary terminal post. Fasten other end of wire to one side of miniature lamp socket. Unscrew nut on one of terminals of socket, wind bare end of other end of this wire around screw stud, and replace nut on stud.

Connect second stripped wire between remaining terminal of lamp

socket and second antenna plate. (Connect antenna plate by looping one bare end of wire through the hole in the plate). Mount flashlight bulb into lamp socket. Attach a rubber band or string through hole at end of second plate (through which one wire end is looped) to support this plate vertically. This is the plate connected to lamp socket. Operate the Tesla Coil. Holding the plate (known as the receiving plate), connect it to the lamp socket by a rubber band or string. Slowly bring toward the other plate mounted to the top of the Coil.

At a certain point the 10-watt lamp will light despite fact there is only one wire connecting it to the Coil.

This experiment illustrates the dream of Nikola Tesla: to send electrical power through the air, without wires, to run factories and homes. Tesla was able to light a bank of 200 lamps at a distance of 20 miles by plugging one wire into the ground and connecting the other to an electrical receiving aerial.

To transmit electrical power without wires in an actual situation, the metallic connection between the suspended receiving plate and Tesla Coil in Experiment 15 would be replaced by the ground return through earth.

### **Experiment 16: How Concentrating Output Produces High Temperatures**

*You Need:*

- Piece of metal (coin, key)
- Sheet of paper

#### **Warning:**

**Perform in Area Where  
Fire Can be Promptly Ex-  
tinguished**

Operate the Coil with the ball terminal in place. Approach the terminal with a piece of metal until discharge occurs in the form of a thin blue spark.

Move the metal closer. The discharge becomes an arc with yellow flame as you approach the terminal.

Take a sheet of paper and hold it

close to the terminal without touching it. Hold a piece of metal behind it to draw discharge through the paper.

Move the metal closer so the discharge becomes an arc. Observe how quickly paper is ignited.

This experiment demonstrates how a high temperature is produced when the entire output of the Coil is concentrated in an arc discharge.

### **Experiment 17: How Air and Metal Compare as Conductors of High Frequency Currents**

*You Need:*

- Piece of Metal.
- 7" bare copper wire, included

Operate the Coil with the ball terminal in place. With a piece of metal, draw out the discharge as far as possible - the *maximum separation* over which a discharge occurs.

Unplug the Coil. Fasten bare wire through the small hole in the primary terminal post by unscrewing the top knob, inserting the tip of wire (bent into small "L") through the hole, and screwing the knob into place.

Bend the free wire upward to project vertically, about 1" or less from the terminal. This is the discharge electrode.

Operate the Coil. Move the free end of the discharge electrode away from the terminal to draw out the discharge as far as possible. Move the wire at its base close to the terminal post. This is the second *maximum separation*. Compare the distances of maximum length created by these two methods.

The length of discharge is greater using the electrode than the piece of metal. The electrode provides a metallic return path for the electrical current, whereas the metal requires that the current pass through the air.

It is impossible to obtain the full output of the Coil in this experiment, due to high resistances offered by your body and the air to the flow of high frequency electrical currents.

### **Experiment 18:** **Demonstrating Principles of Modulation**

*You Need:*

- Piece of metal

This experiment illustrates basic concepts of *modulation*, which is a condition in which a lower frequency can supersede a higher one.

Here the several million cycle per second high frequency-voltage produced by the Tesla Coil is modulated by the 60 cycle per second power line frequency.

Operate the Tesla Coil, holding the piece of metal in your hand.

Move the metal up and down rapidly in a small arc near the ball terminal. Observe that discharges are not continuous but instead occur in the form of individual sparks.

The individual sparks occur at a rate of 120 sparks per second - one discharge at each peak of the 60-cycle power frequency. The Tesla Coil generates a few million cycles per second. Therefore the individual sparks serve to modulate, or bring down to a lower level, the high frequency is generated by the Coil to correspond to a 60-cycle per second modulating frequency.

Experiment with different speeds as you move the piece of metal up and down. You add the dimension of *time* to your observations because at each instant the metal occupies a different position with respect to the terminal.

You may actually be able to make individual sparks appear to stand still, a condition known as *synchronizing*.

When your speed of movement is in step with the 60-cycle per second power line frequency, each discharge appears to occur at the same position in space between the moving metal and ball terminal.

### **Experiment 19:** **Transmitting Power with Radiating Antenna Plates**

*You Need:*

- One 100-200 watt clear glass bulb
- Large radiating antenna plate, tied
- Small antenna plate (included)
- Special lamp socket (included)
- Small length of wire

Mount one radiating antenna plate vertically to the top of Coil by removing the ball terminal, fastening the radiating antenna plate to the screw stud by placing the small hole in the bent 'L' of the plate over the stud and screwing the ball terminal back onto the stud to hold the plate in place. This is the *transmitting antenna plate*.

Attach the special lamp socket to the second radiating plate (*receiving plate*) by threading the small length of wire through both the hole in the bent "L" of antenna plate and the hole in the base of the special lamp socket, then looping the wire over securely.

Place the light bulb in the special lamp socket. Operate the Tesla Coil.

Position both antenna plates so they are parallel to each other. Holding the receiving antenna plate by the glass of the light bulb, approach the transmitting plate, keeping both plates parallel.

Observe the point at which the air in the light bulb ionizes. You must approach the transmitting plate closely when the plates are parallel to each other.

Turn the receiving plate 90° to transmitting plate and repeat. Compare distance at which ionization occurs.

## **Safety Tips and Safety Features:**

This product is designed to be safe when used properly. As with any electrical appliance, please follow these safety rules:

1. Plug into grounded (3-prong) 110 volt 60 cycle outlet only (household current.)  
For **10-206**, plug into 220 volt outlet.
2. Do not operate in wet or damp locations or outdoors.
3. Check for loose, worn or frayed wires. Have defective parts replaced.
4. While high frequency high voltage electricity will not produce a shock, it can cause a burn if taken into your body at one small point of contact. Do not come too close to a discharge; you may be burned. Use a piece of metal to take away discharge so it will not build to unsafe levels of intense heat.
5. Do not open black enclosure. This is a safety guard to ensure your fingers will not come into contact with the vibrator or spark gap.

### **Opening black enclosure is a shock hazard.**

6. Operate the Tesla Coil on a bench or table with a nonmetallic top.
7. Operate the Tesla Coil under adult supervision.
8. Your Tesla Coil is NOT designed to be run continuously, due to heat build up in the vibrator (spark gap). Continuous operation times in excess of 5-10 minutes can cause damage to the unit.

## How to Teach with Tesla Coil:

**Concepts:** High frequency electricity and generation. Resonance in electromagnetic field. Reversed polarity induction.

**Curriculum Fit:** Physical Science, Electricity and Magnetism. *Unit: Moving Charge and Magnets. Grades 11-12*

**Subconcepts:** Primary/Secondary coil. Mutual inductance. Voltage/current relationship during induction. Open and closed circuits, short circuiting. Energy conservation in electromagnetic fields. Transformation of electricity to magnetism, vice versa. Capacitor. Discharge through sparks.

**Curriculum Fit:** Physical Science/Electricity and Magnetism. *Unit: Electric Circuits; Energy Transformation. Static Charge. Grades 6-10*

## Inventor and Invention

Nikola Tesla, born in 1856 in a small village in Yugoslavia, died an American citizen in 1943 after a spectacular career as inventor, visionary and high-society eccentric. A sensation of his time, of his time, he combined photographic memory, ability to visualize complete designs in 3 dimensions, and excellence at languages and math to bequeath to the world his alternating induction motor, high frequency high voltage generator (Tesla Coil), fluid propulsion turbine and innumerable patents.

Eccentric even as a child, Tesla suffered from inexplicable flashes of light when he was in stressful situations and an abnormal sensitivity to noise. He suffered one apparent nervous breakdown at age 5 as a reaction to an older brother's death and two other breakdowns later in life. Yet his original mind was also readily apparent. When introduced to the fascinations of electrical machinery by a teacher, he immediately conceived the idea of dispensing with direct current and com-

mutators in the electric motor. In 1881 he conceived the **rotating magnetic field** by 2 or more alternating current out of step with each other; a year later he built his first actual AC induction motor, using 60 cycle AC which has since been the standard.

Arriving in 1884 in America with an introduction to Thomas Edison, he went to work for the Edison Electric Company. But Edison's heavy investment in direct electric current, as well as personality differences, doomed their relationship. "The War of the Currents" began with mounting hostility, as it would take Edison 20 years to admit his blunder in refusing to recognize the importance of alternating current. Tesla then went to work for George Westinghouse, to whom he sold the 40 patents he had been granted during development of the AC motor, an act for which he would suffer financially in later years.

At this point Tesla seemed at the peak of his creativity. The ideas expressed in four sensational lectures in 1891 - 2 are considered forerunners of: theory of cosmic rays; point electron microscope; atom smasher; diathermy; modern electric clock, and "Litz" wire, a stranded cable. It was also the time in which he developed his **Tesla Coil**, used today in every radio and TV, and in which he conducted research several years before the first experiments of Marconi.

In 1893 occurred 3 triumphs; in St. Louis he made the first public demonstration of radio communication (later a prolonged, bitter war ensued between Marconi and Tesla over radio patents); alternating current was used to illuminate the Chicago World's Fair; and Westinghouse was awarded the contract to build the first 2 generators using AC at Niagara Falls, New York.

Tesla continued to attract media attention. He was an early experimenter with X-rays and robots. In 1898 he innocently set up an "earthquake" by means of vibrations that travelled beneath Manhattan. A bachelor all his life, he attracted the platonic devotion of several women, including J. P. Morgan's daughter, but seemed to have a

close relationship only with his mother, whose death he foretold in a "vision", making him of interest to believers in the occult.

In 1899 he was enticed to Colorado Springs where he set up his famous experimental station with the transmitter he would later claim as his greatest invention. He duplicated electrical fireworks, conducting power-transmission experiments and research into ball lightning. Hearing what was probably radio waves from the stars, he became convinced he had received messages from outer space.

Ridicule and sensationalism now dogged his footsteps. Continually sort of funds, his work languished. What appeared a comeback resulted in the doomed relic of the Wardencllyffe Tower erected on Long Island in 1901. This huge transmitter was intended to be the hub of a world system for broadcasting. It was initially financed by J.P Morgan who withdrew his backing, leaving the tower incomplete.

In later years, although outwardly elegant, Tesla grew bitter, self-serving, defensive and secretive. He continued to produce sensational shows in his laboratory intended to "dazzle" money out of backers. Always, neurotic, he became obsessive, gather up sick and wounded pigeons and carrying them back to his fashionable hotel room to tend lovingly. In his office he worked in the dark, talking to himself.

His creativity remained: in 1906, at age 50, he built his first model of his bladeless turbine. At 72 he filed for patents on his brilliantly designed vertical takeoff and landing aircraft. The advent of World War II led to his publishing the basic principles of what would be known as radar.

In old age he began to court the press, clamoring for attention with predictions for the future. Growing feeble in 1942, he worried about his beloved pigeons, sent a note to Mark Twain - dead for 25 years - and finally died on January 8, 1943 at age 86. 8 months later the Supreme Court handed down the decision he had felt sure would come - that he had invented the radio.

## Tesla Coil Timeline

April 24, 1891. Patent: High Frequency transformers

May 20, 1891. Tesla lectures on *Experiments with High Frequency Currents* at Columbia College

Feb 3, 4 and 19, 1892. Tesla speaks on *Experiments with Currents of Extremely High Frequency* before three profession engineering groups.

1893-1899. Various patents concerning high frequency currents.

## Related Products

**Science First** designs and manufactures a wide range of low-cost labs available from most science education distributors. For more information, please contact us at **1-800-875-3214**.

**615-3100 and 615-3130 Van de Graaf Generators** - With 200,000 and 400,000 volt potentials, respectively. Raise hair, create lightning, experiment with St. Elmo's fire. Excellent instructions with many experiments. Our flagship product.

*Nikola Tesla patented his air core transformer between June 1891 and November 1891 but the better designs were improvements patented in September of 1896. Two sketches are shown here.*

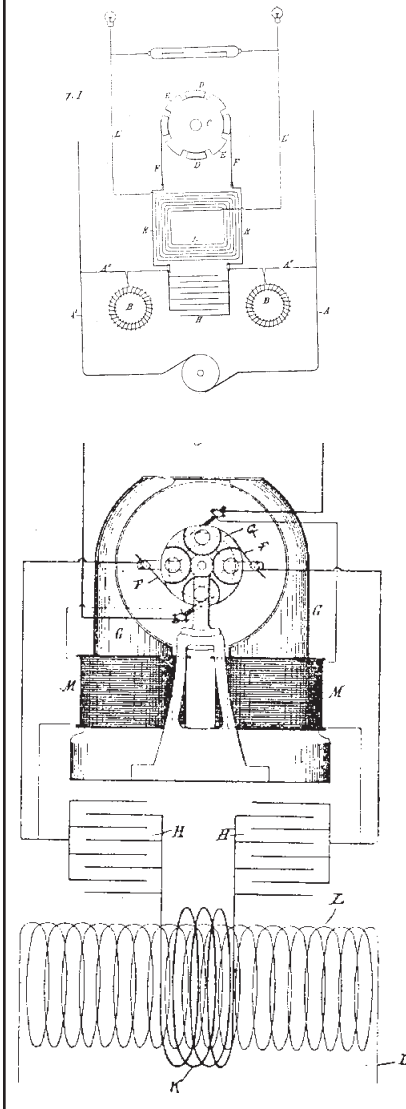

**P/N 24-1205**

© **Science First**/ Morris & Lee Inc. **Science First** is a registered trademark of Morris & Lee Inc. All rights reserved.