

14480 Coulomb's Law Apparatus

Purpose:

To investigate Coulomb's Law of electrostatic attraction and repulsion.

Required Accessories:

Glue (white glue or super-glue)
Hobby knife
Graph paper
Electroscope



Discussion:

The electrical interaction between two charged particles is described in terms of the forces exerted between them. Augustin de Coulomb conducted the first quantitative investigation of these forces in 1784. Coulomb used a very sensitive torsion balance to measure the forces between two “point charges”, that is, charged bodies whose dimensions are small compared to the distance between them.

Coulomb found that the force grows weaker as the distance between the charges increases, and that it also depends on the amount of charge on each body. More specifically, Coulomb's force law states that:

The force of attraction or repulsion between two point charges is directly proportional to the product of the charges and inversely proportional to the square of the distance between them.

The direction of the force on each particle is always along the line joining the two particles; pulling them together when the two charges are opposite, and pushing them apart when the charges are the same.

The force on the “point charges” are measured in this experiment by balancing their electrostatic repulsion against the force of gravity. By suspending a small charged ball with an insulating thread, the electrostatic force can be found by measuring the deflection of the suspended ball from vertical as a second charged ball is brought near. Thus the electric force can be determined from the ball's weight and deflection.

Assembly:

Carefully insert the bottom ridge of the chamber into the slotted base. The front edge of the chamber should be flush with the edge of the base so that the glass window hangs vertically.

Insert a polyethylene insulator rod into the hole at the end of each guide block. Glue a graphite coated sphere onto the tip of the insulator. Lightly scrape the sides of the insulating rod with a sharp knife to remove any residual conducting film (oils from your hands while handling the insulator).

Cut a length of monofilament approximately one meter in length. Fold it in half and pinch the bend in the middle to make a definite crease. Use a small spot of glue to fasten the creased middle of the monofilament to a graphite coated sphere. Allow the glue to dry thoroughly (be patient - don't rush this part!).

Lower the ball into the center of the chamber. Pull the monofilament through the precut slits at the top of the chamber. These slits are centered on the top edge of the front and back faces of the chamber. Once the monofilament has been pulled into the slit, the height and position of the ball can be adjusted by pulling on the free ends of the monofilament. The suspended ball's final position should be the same height as the ball mounted on the guide block and should be centered (front to back) in the chamber.

A mirror is fastened to the back surface of the chamber to help eliminate measurement errors due to parallax. When making measurements, always make sure the ball's image in the mirror is completely covered by the ball itself. This insures that your measurements will be consistent.

Cover the top of the chamber with either the clear or hardboard top to help eliminate the effects of air currents and breezes.

Procedure:

Begin by inductively charging the sphere fastened to the guide block. Vigorously rub the vinyl strip with the wool square. You may hear the crackle of static discharges as you rub the plastic. Bring the coated sphere mounted on the guide block NEAR the charged plastic strip. DO NOT touch the plastic strip with the sphere! When the sphere is close to the plastic briefly touch the sphere with your finger. After you've removed your finger from the sphere, slowly pull the coated sphere away from the charged plastic strip.

The sphere mounted on the guide block has just been INDUCTIVELY charged. Work quickly but carefully. If the air is humid, the charges placed on the coated spheres will eventually "leak off". This takes some time to happen but you should be aware of this fact and work accordingly.

If you touch the charged ball with anything at this point, it will immediately discharge and you will have to charge it inductively again.

Insert the charged ball into the chamber through one of the holes in the base. Gently slide the charged ball up to the suspended ball and bring them into contact. When they touch, the charge will be equally distributed between the two balls. Each ball will have the SAME amount of charge.

What happens just before the balls touch? Did they attract or repel or do nothing? You should notice that just before they touch, the uncharged ball will be drawn toward the charged ball. This only happens at very short distances. These distances are considered short in comparison to the diameter of the balls. With this in mind, can you offer a possible explanation for this attraction at small distances?

Remember, the suspended ball is initially uncharged. This does not mean that the ball has no charged particles on it; it only means that the number of positively charged particles is the same as the number of negatively charged particles, hence the NET charge is zero. Thus, when the charged sphere is brought close to the uncharged sphere, the uncharged sphere becomes polarized. The like charges are forced to the far side of the uncharged sphere and the unlike charges are attracted to the near side. The unlike charges are much closer to the charged sphere than the like charges, so their attractive force is larger than the repelling force of the like charges that are further away, so the two balls are attracted. This is all an example of induction.

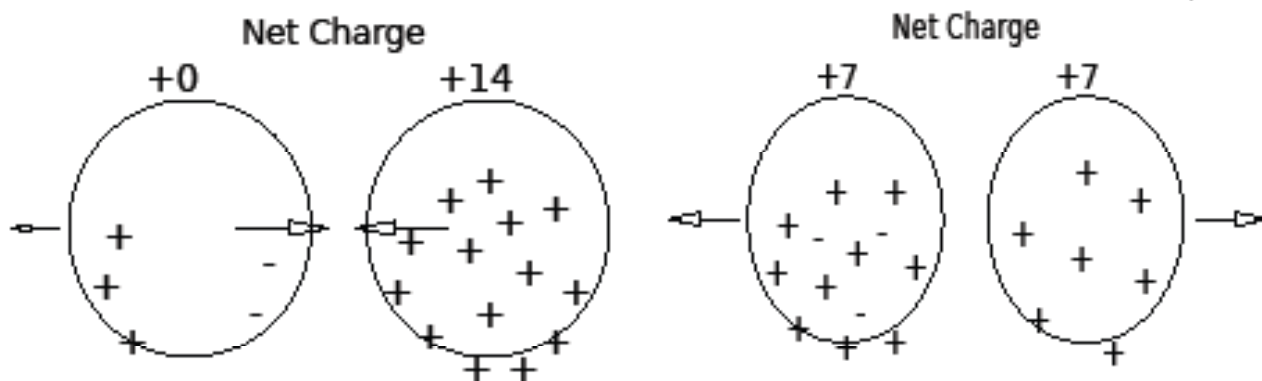

Figure 2
Balls just before contact...

Figure 3
Balls after contact ...

Once the balls have touched, the charge carried by the sphere glued to the guide block is distributed equally between the two spheres and their like charges cause them to immediately spring apart. How far can you electrically "push" the suspended ball away from center before the two balls are forced together again? What happens to the distance between the two balls as the suspended ball is pushed further and further from center?

It may be necessary to charge the two balls several times to get a sufficient repulsive force. Simply charge the ball on the guide block by induction then bring it into contact with the suspended ball. The more charge you put on the suspended ball, the further it will “run away” before you can contact it with the charged ball. It may take a little practice to get the right amount of charge for your situation. Remember, the greater the charge, the greater the displacement and the better the resolution in your measurements.

The following diagram shows a force diagram for the two balls. We will develop a formula from this diagram to express the electrostatic force between the two balls as a function of the suspended balls weight and displacement from equilibrium.

For small angles $\tan(\theta) = d/L$. Looking at the diagram we can see that $\tan(\theta) = F_e/mg$. Combining these equations results in

$$F_e/mg = d/L$$

$$F_e = mg * d/L$$

Where:

- F_e is the electrostatic repulsion between the spheres.
- mg is the weight of the suspended sphere; for this experiment, $mg = 6.5 \times 10^{-4}$ N
- d is the suspended ball’s distance from its equilibrium position (center to center).
- L is the length of the suspension.
- r is the separation between the two balls (center to center)

Since we are not concerned with particular units of force, we can measure the force in terms of d . Therefore we can study the dependence of F_e on r by plotting d as a function of r . Note that the weight given for the suspended sphere is based on its average mass.

Plot a graph of the force as a function of the separation of the two balls (r). What does your graph look like if you plot the force as a function of $1/r^2$? If the graph is linear, then it tells us that the force F_e is proportional to $1/r^2$.

To investigate the way in which the force between the two balls depends on the charges of the balls, recharge them and position the guide block ball (A) near the suspended ball (B) so that the suspended ball is displaced a few centimeters. To change the charge on ball (B), touch (B) with an uncharged ball (C) that has been glued to an insulating rod. The charge on (B) will be equally distributed between (B) and (C) thus leaving (B) with one half of its original charge. Remove ball (C) and note the new distance between the guide block ball (A) and the suspended ball (B).

This process can be repeated to obtain several data points. Plot a graph of the force between the two balls as a function of the product of the charges on the two balls. How does the force depend on the product of the charges?

Time Allocation:

To prepare this product for an experimental trial should take less than fifteen minutes. Actual experiments will vary with needs of students and the method of instruction, but most are easily concluded within one class period.

Feedback:

If you have a question, a comment, or a suggestion that would improve this product, you may call our toll free number.

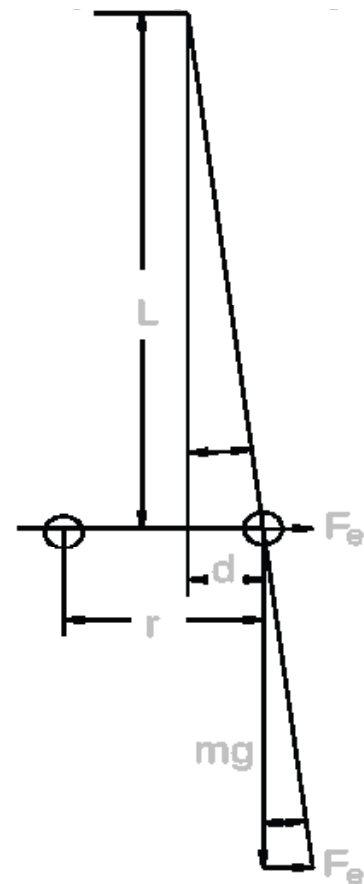

Force diagram for the suspended ball.